

Jan. 17, 1933.

J. L. WRIGHT

1,894,605

BUILDING BLOCK

Filed April 9, 1932

2 Sheets-Sheet 1

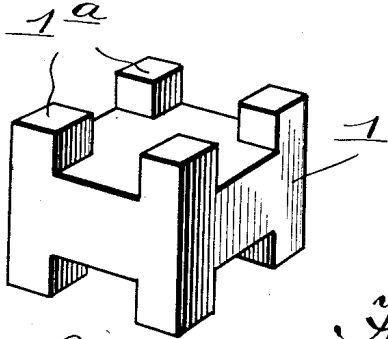

Fig. 1

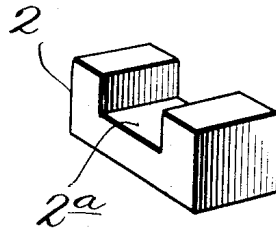

Fig. 2

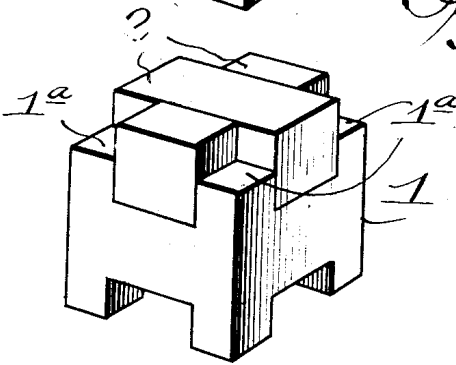

Fig. 3

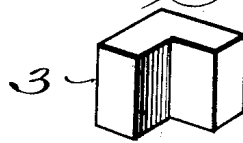

Fig. 4

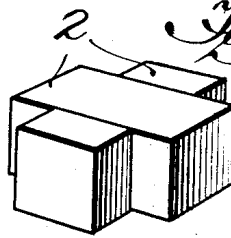
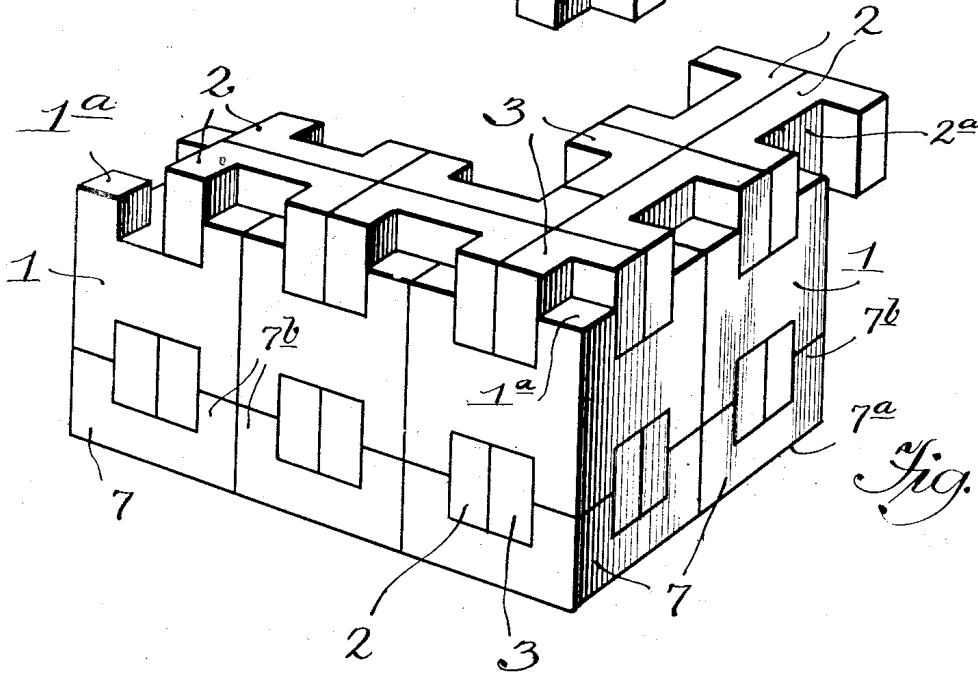

Fig. 5



Witness:
Chas. L. Kousko

Inventor:
John Lloyd Wright,
attorney,
Chicago, Ill.

Jan. 17, 1933.

J. L. WRIGHT

1,894,605

BUILDING BLOCK

Filed April 9, 1932

2 Sheets-Sheet 2

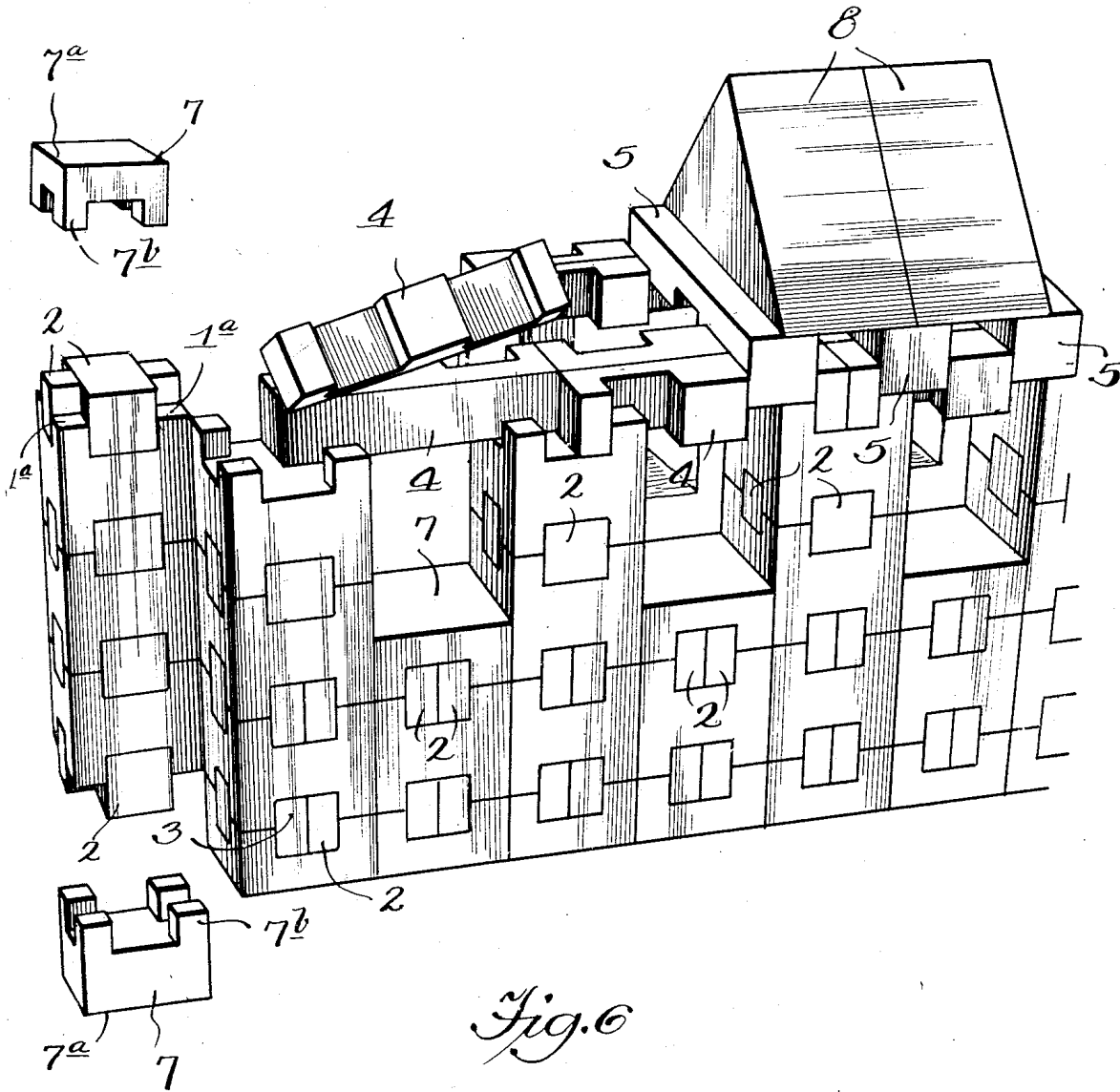

Fig. 6

Witness:
Chas. R. Kourah.

Inventor,
John Lloyd Wright.
Attys.

UNITED STATES PATENT OFFICE

JOHN LLOYD WRIGHT, OF MICHIGAN CITY, INDIANA

BUILDING BLOCK

Application filed April 9, 1932. Serial No. 604,132.

This invention relates to improvements in building blocks for the amusement and instruction of children, and more particularly to the combination of certain foundational or essential pieces which, when combined according to a definite scheme, permit the erection and construction of many different types and sizes of structures, limited only by the number of pieces available.

The object of the invention is to provide a set of building blocks designed not only to afford the child considerable latitude for originality in constructive endeavor, but also to provide the child with blocks which will produce stable structures, that is to say, structures in which the blocks have positive interlocking connection in a horizontal direction and ample stability in a vertical direction to give considerable substantiality to the results of the builder's efforts.

Other novel features of the invention will be made evident from the following description taken with the accompanying drawings, in which

Figure 1 is a perspective view of two key blocks in position for assembling one upon the other, with the interlocking connecting pieces in position;

Figure 2 is a perspective view of one of the connecting pieces;

Figure 3 is a perspective view of a pair of connecting pieces interlocked for assembly in a column;

Figure 4 is a perspective view of one of the L-shaped filler blocks;

Figure 5 is a perspective view of a wall section showing the method of connecting the key blocks and forming a corner; and

Figure 6 is a perspective view of a building detail showing the use of all of the essential blocks and pieces.

The invention can perhaps be best understood by considering first the most essential or primary blocks or pieces of the set, and then taking up the other pieces in the order of their importance in making up a complete set, it being manifest that the more elaborate the type of structures to be constructed, the greater the variety of blocks required, including "special" blocks for completing the

details. These, however, can be added at will, and therefore would not be included in a standard set.

The first block or piece to be identified is the so-called "key" block 1 of the set, so called because it is the main or primary block of any structure. This block is generally cubical in shape, but on two opposite faces the block is grooved centrally and symmetrically in opposite directions so that at each corner of each face are upstanding cubical projections 1^a. As in all building sets, it is essential that the blocks or pieces be cut or fashioned in accordance with a definite dimensional unit, which of course can be varied with the size of the pieces. In this instance $\frac{5}{8}$ of an inch has been selected, and each dimension is therefore a multiple or fraction of this unit. Thus the block 1 may be assumed to be $1\frac{1}{4}$ inches in each dimension, that is, length, width and height, the grooves in the two faces of the block $\frac{5}{8}$ of an inch wide and $\frac{1}{8}$ of an inch in depth, with the result that the cubical projections 1^a are $\frac{1}{8}$ of an inch in each dimension.

Now the next piece in importance to the key block is a tie or connecting block 2 (Figure 2), the same having the general shape of a square letter C and proportioned according to the same dimensional unit. Thus, each of these pieces is $1\frac{1}{4}$ inches in length, $\frac{5}{8}$ of an inch in both width and thickness and having a notch 2^a in one face which is $\frac{5}{8}$ of an inch in width, $\frac{1}{8}$ of an inch in depth, and spaced $\frac{1}{8}$ of an inch inwardly from each end. The pieces of this type are used in several different ways as will be later described.

The third of the primary blocks is a simple angle or L-shaped piece 3 (Figure 4) smaller than the other pieces thus far described, and used primarily as a "filler" piece, that is, to fill cavities or openings in a column or wall, although it also serves to solidify two or more assembled pieces by filling or blocking in spaces that otherwise would permit of a relative movement between pieces. The functions of this block will also be later described in connection with illustrated figures in the drawings.

Perhaps the simplest and most elementary

structure that can be erected would be a column formed by placing one key block 1 upon the other. This could be obviously accomplished merely by placing one upon another with their flat sides in contact, but there would be no connection between them and no stability, since the slightest force would displace them. But the key blocks are placed one upon the other so that they are joined against displacement and with the aid of two of the connecting blocks 2 which are joined together with their notches 2^a interlocked in the form of a cross and then fitted into the grooved face of the lower key block. The second key block is then placed on top of the first, with one of its grooved faces on the underside, as clearly shown in Figure 1. Now, the thickness of the interlocked connecting pieces 2 is equal to the combined depth of the grooves in the opposite faces of the two superimposed key blocks, and moreover fit this cross-shaped space exactly so that the two key blocks are joined together against horizontal displacement. Additional blocks may be added to the column in the same way and thus carried to considerable height without danger of toppling over.

The next step beyond the simple column element would be the erection of a wall element (Figure 5), that is, the act of building horizontally instead of vertically. Here the start would be made by placing two key blocks side by side with the cross grooved faces at the top and bottom. Now to join these blocks together, the same pair of tie blocks 2 are used, but in this case they are placed back to back with their notches facing outwardly and then placed edgewise across from one block to the other filling one-half the grooved spaces in each block, with their oppositely facing notches 2^a embracing the contacting pairs of projecting cubes 1^a. Now, the key blocks are tied together against displacement horizontally, and it will be seen that other key blocks can be added at either end and tied to the wall section already completed and, when a course of any length is completed, another course can be erected on top of it, and so on until a solid wall is completed.

The wall may terminate at a corner and continue at right angles, and to form the corner one key block becomes the corner block, and those on either side would contact with adjacent rather than opposite faces. Moreover in connecting the blocks together with the tie pieces 2, and L-shaped space is left around the outer corner projection 1^a, and herein occurs the first occasion for the use of one of the so-called filler blocks 3 which is set on edge to fill this space, thus closing the apertures or gaps that otherwise would be present in the surface. Another filler block would be used at the inside corner where an L-shaped cavity occurs, due to the fact that the

tie-pieces 2 not having mitered ends cannot meet along the inside row. In other words, only one tie-piece can be extended into the grooved space of the corner block, thus leaving an L-shaped space of just the shape and volume to be filled by a second filler block 3.

Having thus described and illustrated the manner in which the primary pieces are assembled in forming a solid column and wall, the next step is to provide openings in the wall for windows and doors (Figure 6). This then introduces the necessity for pieces to serve as lintels and beams. The lintels 4 are fashioned somewhat after the tie-pieces 2, except that they are longer so that they will span an opening between two blocks equal at least to the width of one of them, in which case the opening may be only the width of one block, but again the opening may be larger, and consequently the beam members are provided in different lengths which are gauged by the number of notches along one edge. Now, these notches as before are $\frac{5}{8}$ of an inch wide and $\frac{1}{8}$ of an inch deep, with a space of $\frac{5}{8}$ of an inch between them and with the endmost notches $\frac{1}{8}$ of an inch from either end. Again, a beam 5 is similar to a lintel except that it is longer, its length being represented by from 3 to say 6 or 8 notches and is used for spanning the distance between the opposite walls of a building and as supports for the roof.

Another very desirable block is what may be termed a one-half key block 7 shown in use in several different locations in the structure of Figure 6. As its name indicates, this block is one-half section of a key block 1 cut on a plane passing midway between the faces having the corner cubical projections, and thus is just one-half the height and has a flat face 7^a opposite one face having the cubical projections 7^b. This block may be used as a sill for a window opening, being inserted horizontally with the flat face uppermost. Again, a row of them may be used as the bottom or base of any wall or other structure. In this case the flat face is at the bottom with the cubical projections extending upwardly, as shown at the bottom of the column at the left of the structure in Figure 6, where the piece is dropped downwardly to show its contour more clearly. And finally, the same block may be used as a cap member, as for the top of the same column at the left in Figure 6, and elevated just above its normal position.

Beyond the blocks or pieces heretofore described, there may be different styles of special pieces, which are for the most part one-half or one-quarter section of some one of the primary pieces. There may be also multiples of some of the pieces, as for example a key block twice as long as the standard block, and so on.

Needless to say, with a greater variety of

blocks, the more elaborate the structure or building that can be reproduced or erected, but even with only the assortment heretofore designated as the primary pieces with perhaps the addition of some of the shorter beam members and a number of triangular shaped roof blocks 8, a child is equipped with all of the necessary materials for erecting many types of structures.

10 Indeed, it is possible to build with these blocks on two different scales, namely, on a large scale in which each piece is merely one element of a building wall, and on a small scale in which each piece may take in entire sections of a building. This fact emphasizes but one of the advantages of a set of building blocks composed of the pieces herein described, namely, the flexibility and the possibility for variations that sustain the child's interest and desire to create something new and different.

Another advantage already alluded to is the stability which accompanies the erection of the structures and is one that further creates and fosters the interest of the child, for it has frequently been demonstrated that a child soon loses interest in building with ordinary blocks, simply because the building or whatever else is being laboriously erected, collapses before it is completed. With the present type of block, the interlocking of the blocks is accomplished as the blocks or pieces are placed one upon the other in the same manner as plain blocks are erected, but with this difference, namely, that the child knows that the structure when finished will be stable and can be preserved as long as he wishes to have it remain intact.

Having set forth a preferred embodiment of my invention, I claim:

1. A set of building blocks comprising cubical blocks, each having one face thereof provided with grooves of a predetermined depth and width intersecting at right angles whereby a cubical projection is retained at each corner, and elongated connecting pieces having a rectangular transverse notch cut in one of the longer faces thereof and adapted to connect a row of said first mentioned blocks by an interlocking engagement with the cubical projections thereof.

2. A set of building blocks comprising cubical blocks, each having a face thereof provided with grooves of a predetermined depth and width intersecting at right angles whereby a small cubical projection is retained at each corner, and elongated connecting pieces having a rectangular transverse notch cut in one of the longer faces thereof and having a thickness greater than the depth of the grooves in said first mentioned blocks, said connecting blocks being adapted to connect said first mentioned blocks together assembled with their grooved faces in the same plane and/or abutting.

3. A set of building blocks comprising a plurality of cubical blocks, each having opposite faces symmetrically cut to form grooves intersecting at right angles, said grooves being substantially one-half the width of said faces and cut to a depth one-half that of their width, leaving cubical portions projecting at each corner of said faces and connecting pieces each having a length equal to, a width one-half that of, and a thickness twice the depth of the said grooves, and having a rectangular notch cut centrally of one of the wider faces of a length and depth equal to the width and depth of the grooves in the first mentioned block, said cubical blocks and connecting pieces being adapted to be joined together vertically and/or horizontally by fitting the latter into the spaces formed by the grooved faces of the former.

4. A set of building blocks comprising cubical blocks, each having a face cut with intersecting grooves forming small cubical projections at the corners thereof, and notched connecting pieces adapted to be assembled in pairs and fitted snugly within the grooves of two of said first mentioned blocks when assembled in horizontal and/or vertical contact.

5. A set of building blocks comprising blocks having a square face cut with intersecting grooves symmetrically arranged to form a cubical projection at each corner thereof, and connecting pieces notched intermediate their ends and adapted to be assembled in pairs, each pair interlocking to form a cross-like member adapted to fit within the grooves of two of said blocks assembled with their corner projections abutting.

6. A set of building blocks comprising cubical blocks, each having a face thereof cut with intersecting grooves forming small integral cubical projections symmetrically positioned at the corners thereof, and connecting pieces adapted to be assembled in pairs to fit within the grooves and interlock with the cubical projections of said blocks for joining a plurality of the same together when assembled in horizontal and vertical relation.

7. A set of building blocks comprising cubical blocks, each having a face provided with grooves intersecting at right angles forming small cubical projections at the corners thereof, and connecting pieces of a thickness substantially twice the depth of said grooves and notched intermediate their ends whereby the same may be interlocked to form a cross adapted to fit snugly within the grooves of two cubical blocks when assembled with their grooved faces abutting.

Signed at Chicago, Illinois, this 1st day of April, A. D. 1932.

JOHN LLOYD WRIGHT.