

PATENT SPECIFICATION



Application Date : Nov. 20, 1933. No. 32235/33.

422,645

Complete Specification Left: June 23, 1934.

Complete Specification Accepted: Jan. 16, 1935.

PROVISIONAL SPECIFICATION

An improved Constructional Building Toy

I, CHARLES BIRD PLIMPTON, of 39, Hamilton Road, Wallasey, Cheshire, a British Subject, do hereby declare the nature of this invention to be as follows:—

This invention relates to a constructional toy by means of which models of buildings or the like may be built and assembled from a series of interchangeable parts.

According to this invention a series of panels, slabs, frames or the like units are superimposed one upon another edge to edge the edges of each unit being grooved or formed with lugs so that they may engage a series of spaced rods. The panel units have preferably grooves along two opposite sides, such grooves engaging between the rods in such manner that when panel units are positioned on each side of a rod the rod is enclosed between the grooves and a continuous surface is presented by the assembled panels. The units may be made in metal and either grooved at their edges or having staggered loop lugs, or they may be made in some moulded plastic composition. The retaining rods with which the edges of the panels or slabs engage may be arranged vertically, horizontally or otherwise and in order to form corners or angular dispositions of the walls or the like of the model buildings, the edges of certain of the panel units may be mitred or bevelled.

The rods forming the retaining framework for the panels are secured in holes or sockets in a base plate in the case of vertical rods, or in vertical members in the case of horizontal rods, and the rods may either be merely inserted into the holes or screwed therein, or the feet of the rods may be headed to enter corresponding recesses in the undersurface of the plate to retain the rods securely. The base plate may be in one piece or put together in sections, tongued and grooved or otherwise connected, and the socketed member which engages the tops of the vertical rods may for the purpose of constructing model buildings be formed with an imitation gutter, or with a ledge for

holding the roof. When the series of vertical rods have been inserted into the base plate the panels, slabs or the like are then dropped vertically into position, their grooved side edges engaging and sliding down the rods so that a horizontal series of panels abut together completely enclosing the vertical frame rods.

The panels may be made of any suitable size and shape and it is desirable that the dimensions of the larger panels should be multiples of the smallest panel or the like in the series.

When the wall has been completed the top socketed retaining member for the vertical rods is positioned thereon and the roof may then be built up either in the same way as that described, by means of a series of spaced rods with which a number of panels are slidably engaged, or a roof may be put on in complete sections. Where it is desired to provide window frames or door frames in the model building, these units are similarly formed with grooved sides to enable them to be engaged with the rods.

The panels or sections if made in some moulded plastic material may be recessed at the back for lightness and the front surface may be lined to imitate brickwork and the panels tinted in suitable colours. Similarly the window frames may consist of framed pieces glazed and having imitation window sashes.

Instead of the units having grooved sides for engaging the rods they may be provided with looped lugs, this form being particularly suitable where the panel elements are made of metal, and such looped lugs on opposite edges of each panel are relatively staggered, say, a higher lug on the left side and a lower lug on the right side, and in this way when a horizontal row of such panels are being assembled on their rods the staggering of the lugs enables the series to be brought horizontally in line.

Dated this 18th day of November, 1933.

A. J. DAVIES,

Patent Agent,

24, Moorfields, Liverpool.

COMPLETE SPECIFICATION

An improved Constructional Building Toy

I, CHARLES BIRD PLIMPTON, of 39, Hamilton Road, Wallasey, Cheshire, a British Subject, do hereby declare the nature of this invention and in what
5 manner the same is to be performed to be particularly described and ascertained in and by the following statement:—

This invention relates to a constructional toy of the kind in which models of
10 buildings or the like may be built and assembled from a series of interchangeable parts.

A constructional building toy according to the present invention comprises a
15 base, of for example moulded material, having a plurality of equidistantly pitched holes into which are adapted to be inserted the bottom ends of vertical rods, such rods serving as a framework
20 for supporting building panels, slabs or the like which are grooved along two opposite vertical edges and received between a pair of vertical rods with the grooves in engagement with the rods.

In a suitable embodiment the vertical rods may be of round section and the vertical grooves in the panels of semi-circular cross-section so that in the assembled building a series of panels abut
25 together to enclose the frame rods completely. The base may be of one-piece construction, or built up from a number of sections, the arrangement of the holes in the latter case being such that when
30 the sections are connected together the holes in the resulting base are equidistantly pitched.

Additional frame rods arranged horizontally or otherwise may also be provided.
40 In order to form corners or angular dispositions of the walls or the like of the model buildings, the edges of certain of the panel units may be mitred or bevelled, or special corner pieces may
45 be provided.

The rods forming the retaining framework for the panels are secured in holes or sockets of the base plate in the case of vertical rods, or in vertical members in
50 the case of horizontal rods, and the rods may either be merely inserted into the holes or screwed therein, or the feet of the rods may be headed to enter corresponding recesses in the undersurface of the plate to retain the rods securely. A
55 socketed member or members may engage the tops or some intermediate part of the vertical rods for the purpose of definitely locating the rods in their correct spaced
60 relation, and be formed when at the top with an imitation gutter, or with a ledge

for holding the roof. When the series of vertical frame rods have been inserted into the base plate the panels, slabs or the like are then dropped vertically into
65 position, their grooved side edges engaging and sliding down the rods so that a horizontal series of panels abut together completely enclosing the vertical frame rods.

The panels may be made of any suitable size and shape and it is desirable that the dimensions of the larger panels should be multiples of the smallest panel
70 or the like in the series.

When the wall has been completed the top socketed retaining member for the vertical rods is positioned thereon and the roof may then be built up either in the same way as that described, by means of
75 a series of spaced rods with which a number of panels are slidably engaged; or alternately, a one-piece roof of say moulded material may be positioned on ends of vertical frame rods projecting
80 above the walls of the building, in such manner as definitely to locate the frame rods in their correct spaced relation corresponding to the pitch of the holes in the base, the top socketed member or
85 members being then dispensed with. Where it is desired to provide window frames or door frames in the model building, these units are formed with oppositely grooved edges to enable them
90 to be engaged with the rods.

The panels if made in some moulded plastic material may be recessed at the back for lightness and the front surface may be made to imitate brickwork or
95 Stucco work and the panels tinted in suitable colours. Similarly the window frames may consist of framed pieces glazed and having imitation window sashes.

Various embodiments of the invention are shown by way of example in the accompanying drawings, in which:—

Fig. 1 is a front elevation of a toy bungalow-type of building assembled
100 from panel units and other parts according to the invention.

Fig. 2 being a plan view of the building and base with the roof removed, and

Fig. 3 an underside view of an alternative form of base built up from sections.
115

Fig. 4 is an underside view of the roof, and

Fig. 5 a section on the line *a—*a** thereof.
120

Fig. 6 shows in front elevation the arrangement of the upstanding rods on

the base which are engaged by the panel units, and the manner in which the roof is supported.

Fig. 7 is an underside view of an alternative form of roof, and

Fig. 8 a section on the line *a—**a* thereof.

Figs. 9, 10 and 11 are front, plan and rear perspective views respectively of a building panel or slab.

Figs. 12 and 13 are front and sectional views respectively of a window frame,

Fig. 14 being a view corresponding to Fig. 13 showing a modified form of window frame having means for retaining a celluloid or like window.

Figs. 15 and 16 are front and sectional views respectively of a door panel.

Figs. 17 and 18 show in plan view alternative forms of special right-angled corner pieces,

Fig. 19 being a perspective view of a further form, and

Fig. 20 a plan view showing the manner in which the corner piece of Fig. 19 is utilized.

Fig. 21 is a plan view showing the manner in which doors and window frames may be adapted for hingeing.

Fig. 22 is a broken view of two abutting modified forms of panels with means for maintaining the vertical frame rods in their correct spaced relation,

Fig. 23 being a section on the line *a—**a* of Fig. 22.

Referring to Figs. 1, 2, 4 and 6, the bungalow-type of building shown is assembled on a base 1 of say plywood or moulded plastic material. The upper face of the base is provided with a number of equidistantly pitched holes 2 adapted to receive straight vertical round-section rods 3 of various lengths, which are inserted into selected holes according to the building to be erected. The walls of the building are built up from panels 4 engaging the spaced rods 3, and the bungalow surmounted by the moulded one-piece roof 5.

In place of the base 2 there may if desired be used a base built up of interchangeable sections 6 shown in the underside view of Fig. 3, which are secured together by means of metal strips 7, secured within co-operating recesses 8 at the edges of the sections by small screws 9. The upper faces of the sections are provided with holes for receiving the rods 3, the holes being so disposed that when the sections are connected together the holes are equidistantly pitched as with the one-piece base of Fig. 2.

The one-piece roof shown in the underside view of Fig. 4 is located in position on portions of the upstanding rods 3 pro-

jecting above the top of the walls of the bungalow, Fig. 6, the ends of the rods engaging a recess 10 extending round the underside of the roof, such recess 10 being tapered, Fig. 5, with the width of the mouth of the recess somewhat greater than the diameter of the rods so as to permit of ready positioning of the roof. If desired, the recess 10 may be replaced by a series of holes 11, Fig. 7, spaced to the same pitch as the holes 2 in the base, these holes 11 being tapered for the same purpose as that for the tapered recess 10, and definitely locating the rods in their correct spaced relation.

The panels 4 from which the walls of the building are assembled are indicated in Figs. 9, 10 and 11. They are preferably of moulded plastic material, suitably coloured, and having their front faces lined in imitation of brickwork. The panels are of square or rectangular shape of a width equal to say twice the pitch of the holes 3, or any other multiple of the pitch, with two opposite edges formed with semi-circular vertical grooves 12, which are adapted to engage a pair of the spaced rods 3, the panels being dropped vertically into position between the rods so that a horizontal series of panels abut together to completely enclose the vertical rods. Each of the panels is provided at its rear face with a central channel or recess 13 for receiving the abutting ends of adjacent walls in the manner shown in Fig. 2.

Within the walls of the building are provided window frames 14, (Figs. 12, 13, 14) and doors 15 (Figs. 15, 16) grooved along their vertical edges and being of the same width as the panels 4 but of somewhat greater depth, say one-and-a-half and double the depth respectively, the space of half a panel in the case of the window frame being filled in by a special half panel 16 (Fig. 1). A window of flexible material such as transparent celluloid may be flexed or slipped into position behind lugs 13*a* on the window frame.

The corners of the building are preferably made with the special corner pieces 17 shown in the views of Figs. 17, 18, 19 and 20. Each of the two sides of the corner pieces 17 corresponds in size and purpose to a panel 4, and with the construction shown in Fig. 17, semi-circular grooves 18 are formed in the vertical edges of the panels and a vertical hole 19 drilled at the corner, the grooves 18 and hole 19 engaging three adjacent vertical rods 4 at the corners of the building.

In making these corner pieces difficulty is found in getting a clean moulding at

70

75

80

85

90

95

100

105

110

115

120

125

130

the grooved edges 18 of the corner pieces, and it is therefore preferred to shape the vertical edges of the corner pieces to the form shown in Figs. 18 and 19, the grooves 18 being replaced by a recess formed by steps 20, which engage the rods 3 in the manner shown in Fig. 20.

The holes 19 at the corners of the corner pieces are produced by drilling, and as there is a tendency for the drill to drift in view of the length of the hole and the smallness of the drill, the length of the hole is shortened (Fig. 19) by the provision of an inner recess 21 in which is received a jig for guiding the drill after it has penetrated a short distance in the corner piece.

As shown in Fig. 21 the doors and windows may be adapted for hingeing by providing them with a vertical hole 22 received by a vertical frame rod 3, the holed side 24 of the frame being of circular formation and engaging a correspondingly shaped vertical recess at the edge of the adjacent panel 4 so as to allow of opening and closing of the door or window. The free vertical edges of the hingeable doors and windows are stepped as shown at 25 so that they abut against a frame rod 3 when closed.

Instead of the units having grooved edges for engaging the rods they may be provided with looped lugs, which may for example be of metal secured in the moulded plastic material of the panels or formed integrally with panels made of sheet metal; and such looped lugs on opposite edges of each panel are relatively staggered, say, a higher lug on the left side and a lower lug on the right side, and in this way when a horizontal row of such panels are being assembled on their rods the staggering of the lugs enables the series to be brought horizontally in line.

In order to ensure the spaced frame rods 3 being maintained in their correct spaced relation and so prevent the panels 4 from becoming displaced through incorrect spacing, as might occur when the rods are of considerable length in a tall building, the frame rods 3 may be connected together and spaced, at say the floor levels of the building, by a horizontally-disposed strip element or series of links or by a single piece floor element. The strip element or links or floor element are apertured to the same pitch as the holes in the base 1, and when the walls of the building have been built up to a certain level with the panels 4, a member 25 or floor element is slipped over the frame rods 3, the erection of the walls being then continued. The members 25 may in the case of panels

made of moulded plastic material be received within a horizontal recess 26 at the rear faces of the panels, such recess being produced by stepping the horizontal edges of abutting panels.

Having now particularly described and ascertained the nature of my said invention and in what manner the same is to be performed, I declare that what I claim is:—

1. A constructional building toy of the kind referred to comprising a base, of for example moulded material, having a plurality of equidistantly pitched holes into which are adapted to be inserted the bottom ends of vertical rods, such rods serving as a framework for supporting building panels, slabs or the like having grooves or recesses along two opposite vertical edges which are received between a pair of vertical rods with the grooves or recesses in engagement with the rods.

2. A constructional building toy according to Claim 1, wherein the vertical frame rods are of round section, the vertical grooves in the panels being of semi-circular cross section.

3. A constructional building toy according to either of the preceding claims, wherein the rear face of each panel is provided with a vertical recess or groove for receiving the abutting end of a panel forming the end of an adjacent transverse wall.

4. A constructional building toy according to Claim 1, wherein the base is built up from a plurality of sections each having holes for receiving the vertical rods, the arrangement of the holes in the sections being such that when a plurality of such sections are connected together to form the base the whole series of holes in the base are equidistantly pitched.

5. A constructional building toy according to Claim 4, wherein the sections are connected together by means of strips in co-operating recesses on the underside edges of abutting sections.

6. A constructional building toy according to Claim 1, wherein the corners to the building are constructed from corner pieces comprising a pair of panels moulded or otherwise suitably formed in integral right-angled relation, the corner pieces being vertically apertured at the angle and recessed at the two free vertical edges of the panels to slidably receive the three vertical rods forming the corner to the framework of the building.

7. A corner piece according to Claim 6, wherein an inner recess is provided at the junction of the two panels leaving material only at the top and bottom of

70

75

80

85

90

95

100

105

110

115

120

125

130

the corner through which the vertical hole at the corner is made.

8. A corner piece according to Claim 6, wherein the recesses at the two free vertical edges of the panels comprising the corner piece are formed by stepped portions for the purpose specified abutting against co-operating vertical frame rods.

9. A constructional building toy according to Claim 1, wherein there are provided panels shaped to the form of window frames and doors, such frames and doors being grooved along two opposite vertical edges to engage between a pair of the vertical frame rods.

10. A window frame according to Claim 9 having a window of flexible material such as transparent celluloid which is flexed or slipped into position behind lugs on the window frame.

11. A constructional building toy according to Claim 1, wherein there are provided panels shaped to the form of window frames or doors, such frames or doors being adapted for hingeing, one of the vertical sides of the frame or door having a vertical hole so as to enable its being received by and hingeable on a vertical frame rod, the holed side of the frame or door being of circular formation and engaging a correspondingly shaped vertical recess at the edge of the adjacent panel to allow of opening and closing of the window or door.

12. A constructional building toy according to Claim 1, wherein the recesses along the vertical edges of the panels are presented by looped lugs, such looped lugs being relatively staggered on opposite edges for the purpose specified.

13. A constructional building toy according to Claim 12, wherein the looped lugs are of metal secured in moulded plastic material forming the basis of a panel.

14. A constructional building toy according to Claim 12, wherein the

looped lugs are formed integrally with panels of sheet metal.

15. A constructional building toy according to Claim 1, wherein the vertical frame rods are connected together and maintained in their correct spaced relation above the level of the base by means of a horizontally-disposed floor element or links apertured to the same pitch as the holes in the base.

16. A constructional building toy according to Claim 15, wherein the horizontal floor element or links are received within a recess at the rear faces of abutting panels produced by stepping the horizontal edges of the panels.

17. A constructional building toy according to Claim 1, having a one-piece roof of for example moulded material which is located in position on portions of the vertical frame rods projecting above the walls of the buildings.

18. A one-piece roof according to Claim 17, wherein the projecting ends of the frame rods are received in and located by a recess disposed round the underside of the roof.

19. A one-piece roof according to Claim 17, wherein the projecting ends of the frame rods are received in and positively located by a series of holes spaced to the same pitch as the holes in the base and disposed round the underside of the roof.

20. A one-piece roof according to either of Claims 18 or 19, wherein the recess or holes are of tapered formation with the mouth of the holes or recess somewhat larger than the diameter of the frame rods so as to allow of ready positioning of the roof.

21. A constructional building toy substantially as described with reference to the accompanying drawings.

Dated this 18th day of June, 1934.

A. J. DAVIES,
Patent Agent,
24, Moorfields, Liverpool.

[This Drawing is a reproduction of the Original on a reduced scale.]

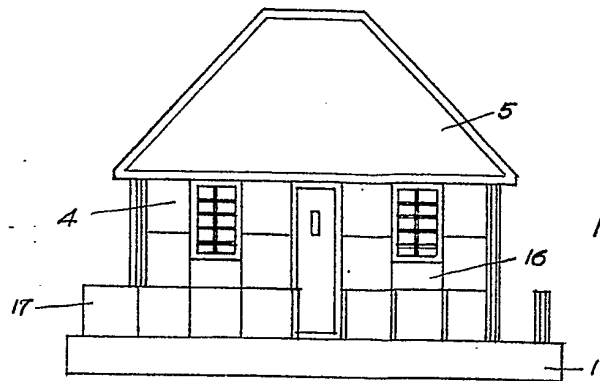

FIG. 1.

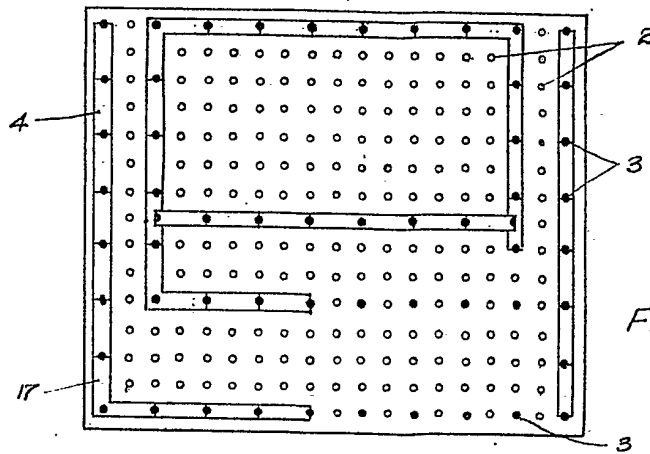

FIG. 2.

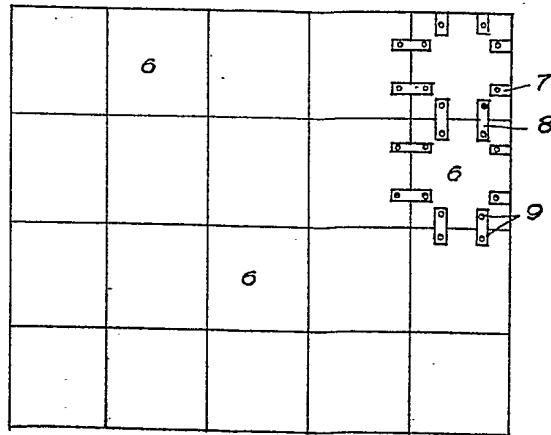

FIG. 3.

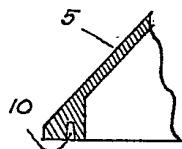

FIG. 5.

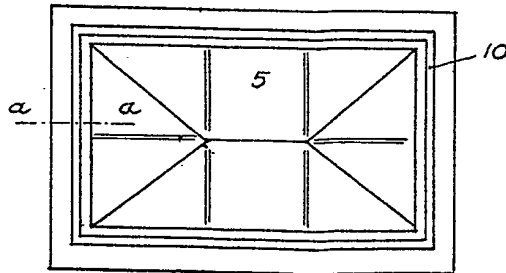

FIG. 4.

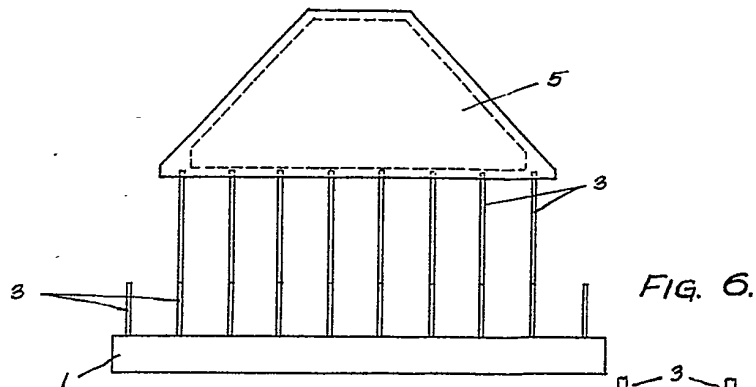

FIG. 6.

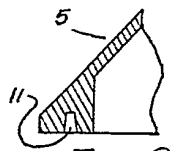

FIG. 8.

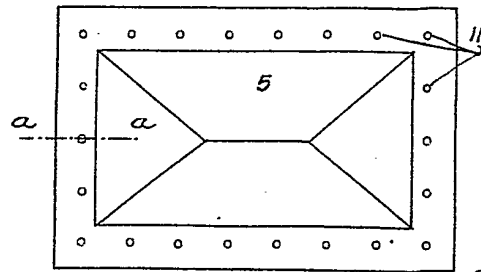

FIG. 7.

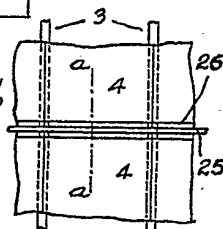

FIG. 22.



FIG. 23.

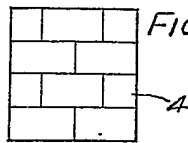

FIG. 9.

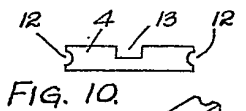

FIG. 10.

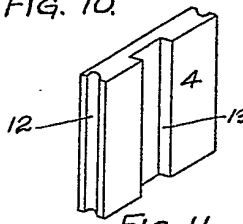

FIG. 11.

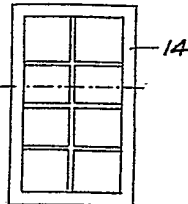

FIG. 12.



FIG. 13.



FIG. 14.

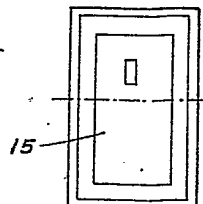

FIG. 15.

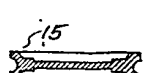

FIG. 16.

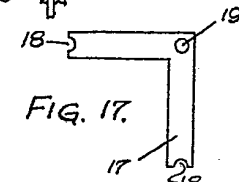

FIG. 17.

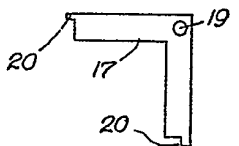

FIG. 18.

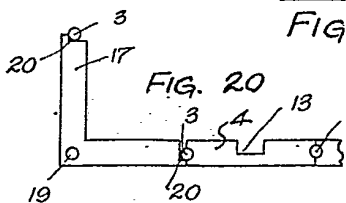

FIG. 20.

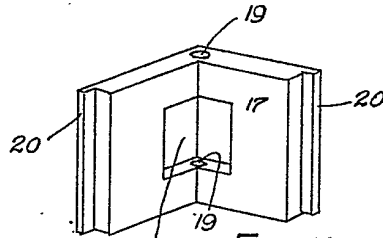

FIG. 19.

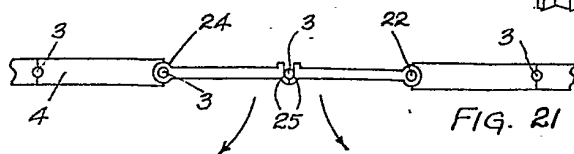
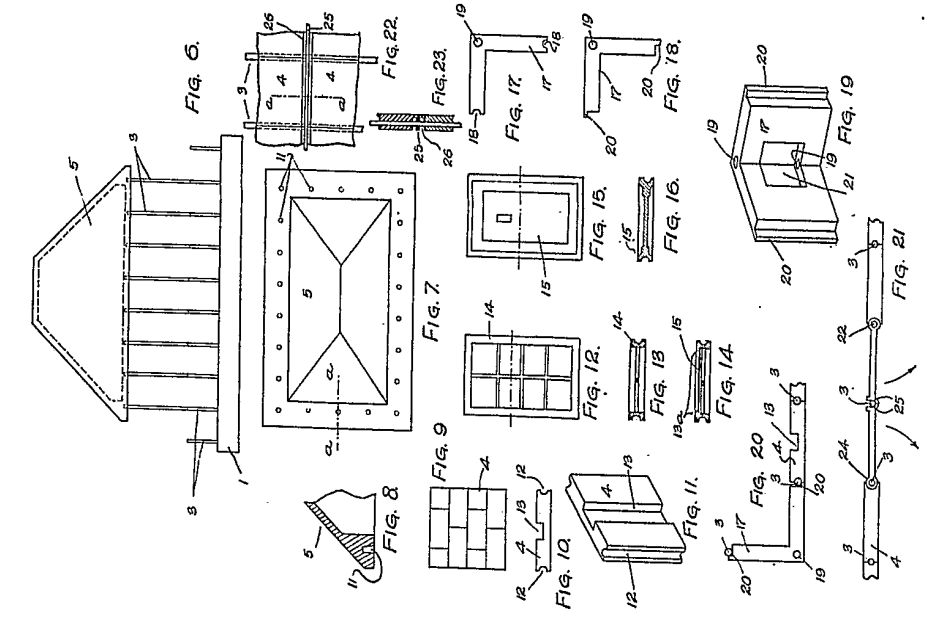
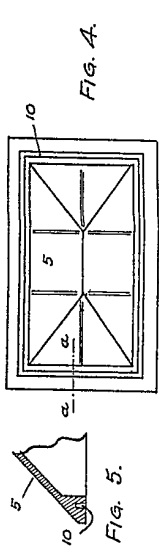
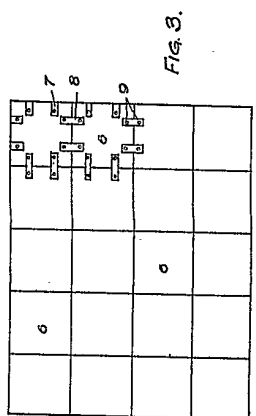
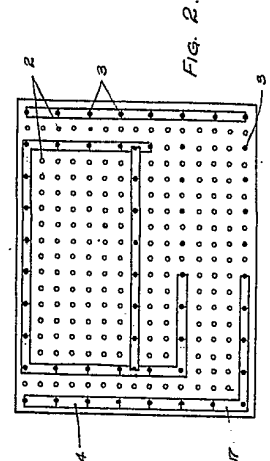
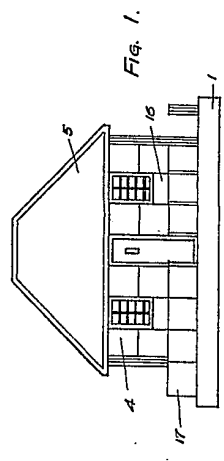

FIG. 21.



[This Drawing is a reproduction of the Original on a reduced scale.]